



# HYDRAULIC PRESSES



*Precision in YOUR work*





# Technical Solutions for YOUR work

## The Company

Innovation, reliability, safety, accuracy are our core values.

**AxA** was founded in 1985 and we have since specialised in constructing hydraulic presses and counterbalanced workshop cranes.

Thanks to our multi-year experience, we can produce technical solutions tailored to meet our customers' special requirements.

We also build on that experience to develop new models, because

we strongly believe in innovation. Before accessing the production phase and acquiring **AxA** mark our prototypes are rigorously tested.

Our long history proves the quality of our made in Italy production. We have been chosen as business partner by well-known companies in Italy and abroad.

We are indeed located in Emilia Romagna, at the heart of the Italian Motor Valley, an area in the North of the Country with centuries-old tradition in the mechanic sector – particularly

automotive, that has produced some of the world best Brands. In this land, rich in technical schools and laboratories, we have grown up surrounded by the nice and unique blend of passion, tradition and innovation.

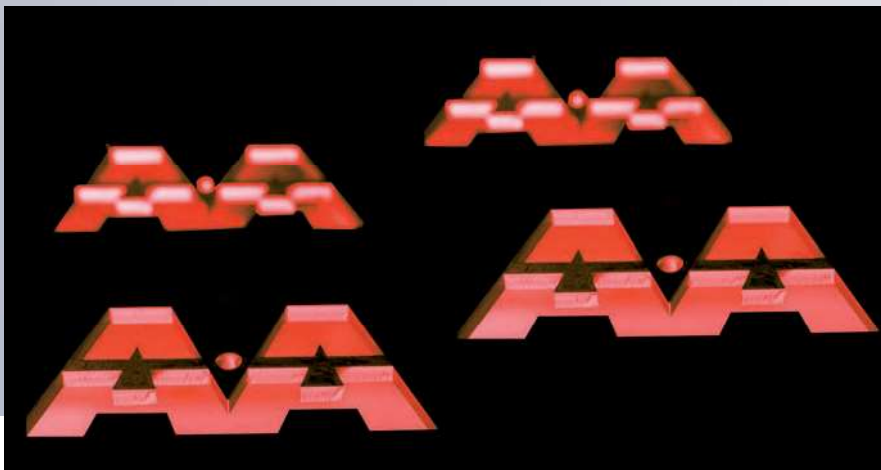

Innovation, reliability and safety  
are our core values



Precision in YOUR work

## HYDRAULIC PRESSES

Designed and manufactured by **AxA Group**, our hydraulic presses are of excellent build quality, guaranteed by severe controls at each stage of the production process, up to final testing.

We pay great attention to details: all Made in Italy components, supplied by certified producers and verified through a modern supply chain.

Our presses come with an extra-solid structure: frame is entirely laser-cut, with monolithic uprights and no welded points in strained areas. They are compliant with EU Directives and CE marked.

**AxA** produces the power units as well.

Standard models, always available in stock, range from 12 to 150 tons of max capacity. Furthermore, we manufacture special presses

tailored on clients' specific requirements of height, length, thickness, cylinder stroke, speed.

A full range of standard and special accessories is also available to make our machines suitable for many applications: V blocks, working tables, plates, perimeter protections, limit switch, anti-rotation devices.



AxA Hydraulic Presses are essential equipment in any factory



12 / 20 tons

## P12B / P12 / P12P / P20 / P20P MANUAL HYDRAULIC PRESS, FLOOR MOUNTED AND WITH PNEUMATIC FOOT PUMP

**P12** press comes in three versions: on stand (**P12B**) floor mounted (**P12**) with pneumatic foot pump (**P12P**). **P20** press comes in two versions: floor mounted (**P20**) with pneumatic foot pump (**P20P**).

Heavy duty, **entirely laser-cut**. Equipped with a double-speed pump: fast mode for low pressure and slow mode for high pressure. Cylinder is fitted with a spring return device and a pressure gauge.

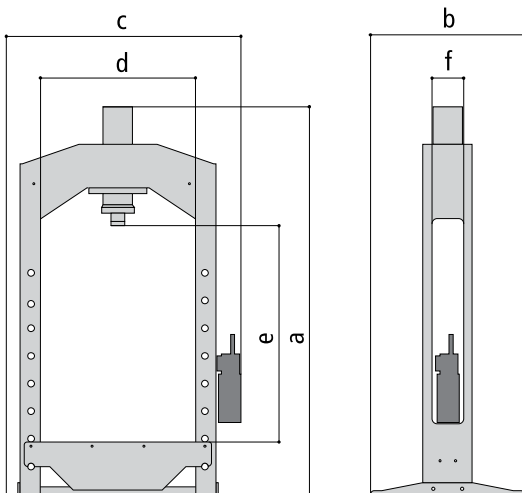

Technical data						
	UM	P12B	P12	P12P	P20	P20P
<b>Max capacity</b>	[tons]	12	12	12	20	20
<b>Weight</b>	[kg]	90	100	100	110	110
<b>Max pressure</b>	[bar]	400	400	400	400	400
<b>Speed in fast mode</b>	[l/min]	3,2	3,2	3,2	3,2	3,2
<b>Speed in slow mode</b>	[l/min]	0.28	0.28	0.28	0.28	0.28
<b>Cylinder stroke</b>	[mm]	190	190	190	190	190

Dimensions						
	a	b	c	d	e	f
<b>P12B</b>	1240	530	800	510	400	80
<b>P12</b>	1860	530	800	510	1020	80
<b>P12P</b>	1860	530	740	510	1020	80
<b>P20</b>	1890	590	910	510	1040	80
<b>P20P</b>	1890	590	860	510	1040	80